



SIMARINE®



STR1

USER MANUAL

V1.0

STR1

© 2026 SIMARINE

All rights reserved. No parts of this work may be reproduced in any form or by any means - graphic, electronic, or mechanical, including photocopying, recording, taping, or information storage and retrieval systems - without the written permission of the publisher.

Products that are referred to in this document may be either trademarks and/or registered trademarks of the respective owners. The publisher and the author make no claim to these trademarks.

While every precaution has been taken in the preparation of this document, the publisher and the author assume no responsibility for errors or omissions, or for damages resulting from the use of information contained in this document or from the use of programs and source code that may accompany it. In no event shall the publisher and the author be liable for any loss of profit or any other commercial damage caused or alleged to have been caused directly or indirectly by this document.

1. Introduction	5
2. Overview	7
3. Preparation	9
4. Installation	11
5. Sender Wiring	15
5.1 General Wiring	17
5.2 Simarine Specific Wiring	19
5.3 Victron Specific Wiring	22
5.4 Mixed System Wiring	23
6. Sender Configuration	25
6.1 First Time Configuration	26
6.2 Manual Calibration of an irregular-shaped tank	28
6.3 Manual Calibration	30
6.4 Firmware upgrade	32
6.5 Factory Reset	33
7. Technical specification	35



1. Introduction

The Simarine radar tank level sender STR-1 is a versatile solution for accurately monitoring the level of liquid in your tank. With three analogue signal outputs, a single sender can simultaneously provide level information to three separate gauges, allowing flexible integration into various monitoring systems. In addition, the STR-1 sender can be monitored via the dedicated mobile application using Bluetooth communication.

2. Overview

Self-Calibration and Advanced Calibration

The sender automatically performs a basic calibration between **empty** and full **states**.

For tanks with **irregular shapes**, you can calibrate it manually by inputting the calibration points to achieve maximum measurement precision.

Invalid Measurement Detection

If the sender detects an invalid measurement - such as when the tank is **tilted beyond the permissible angle** - the device will temporarily stop updating the output. Until a new valid measurement is available, all analogue outputs will continue to provide the **last known correct value**.

Power interruption

In the event of a power interruption, **all sender configurations are preserved**. When power is restored, the sender automatically resumes normal operation and continues providing accurate level measurements without requiring any additional setup.

Recalibration and Factory Reset

If calibration was performed incorrectly or requires adjustment, the sender can be recalibrated. This process requires performing a factory reset and repeating the full calibration procedure from the beginning.

Mounting Instructions

The mounting adhesive creates a very strong bond between the tank surface and the sender.



For this reason:

- Choose the mounting position carefully.
- Avoid relocating the sender after installation, as adhesion strength will be significantly reduced.
- To remove the sender, you may need to use an X-Acto knife or another sharp tool to carefully separate it from the bottom edge of the device. Do not apply excessive force - this may damage the casing.

Mechanical damage voids the warranty.



3. Preparation

	<p>Ensure the mounting point is chosen carefully.</p> <p><u>Removing the sender after initial installation will degrade the effectiveness of the adhesive bond during reinstallation at any new location.</u></p> <p><u>Before mounting the sender, ensure that all the mounting conditions listed under the “INSTALLATION- Step 1” section of this document are met.</u></p> <p><u>The wall thickness of the tank must not exceed 10 mm.</u></p>
	<p>It is crucial that the mounting surface is thoroughly cleaned before mounting the sender.</p> <p><u>After cleaning the mounting surface, allow it to dry completely before mounting the sender.</u></p> <p><u>This also applies to brand-new tanks.</u></p>
	<p>Do not provide power to the sender until after the installation and the wiring as per this manual.</p>

If you need any assistance, our support team is available at support@simarine.net and will be happy to help you

4. Installation

Do not begin mounting the sender before carefully reading the important preparation instructions on the previous page.

STEP 1: Carefully select the mounting point where you will mount the sender to:

- Ensure that the sender will be mounted on the top of the tank (preferably in the centre).
- Ensure that the sender will be mounted perpendicularly to the surface of the liquid in the tank.
- Ensure that the sender will have a direct, perpendicular “line of sight” of the bottom of the tank.

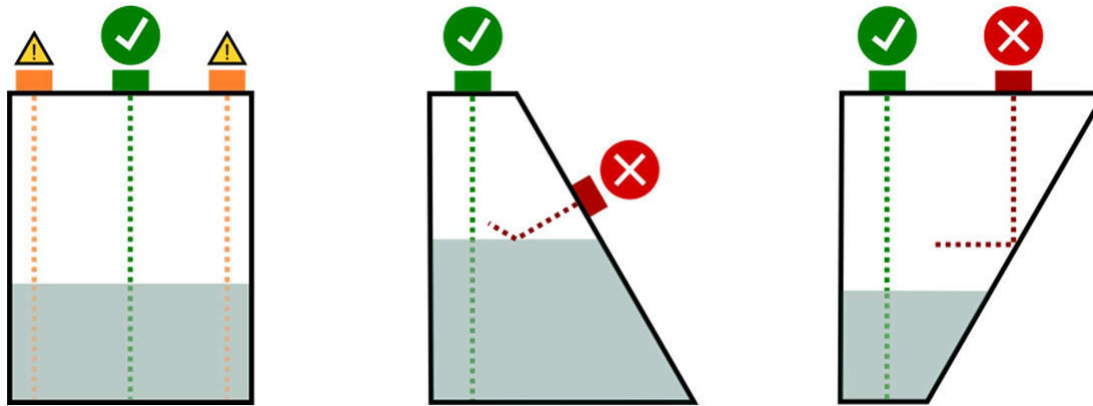

Good mounting point.



Try to find a better mounting spot if possible.



Invalid mounting point - the sender will not work.

STEP 2: Use the included alcohol preparation pad to ensure the mounting surface is thoroughly cleaned before installation.

STEP 3: Let the cleaned mounting surface dry completely.







STEP 4: When ready to mount the sender, peel off the bottom side of the adhesive tape from the sender and firmly press the sender to the mounting point on the tank. Please note that the adhesive requires 24 hours to achieve full bonding strength with the tank, but the wiring and configuration may be carried out immediately.



5. Sender Wiring

	<p>Ensure that all unused wires are properly insulated before powering the sender to prevent short circuits.</p>
---	--

The **GND** and **COM** connections inside the sender are **galvanically isolated**, ensuring stable readings and preventing interference from other devices in the system.

Wire	Function	Description
	Red	8 - 35 VDC Power source connection
	Black	GND Power source connection
	Green	0 - 5 VDC Voltage output
	White	0 - 190 Ohm Resistive output (European standard)
	Yellow	240 - 30 Ohm Resistive output (American standard)
	Blue	COM Virtual ground (Galvanically separated from GND)

5.1 General Wiring

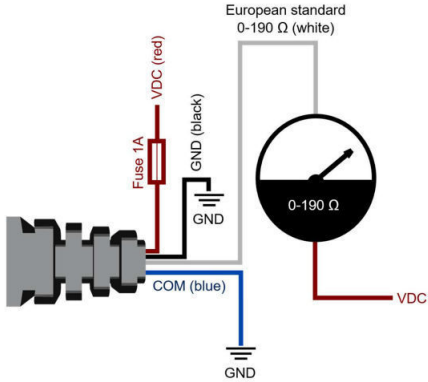
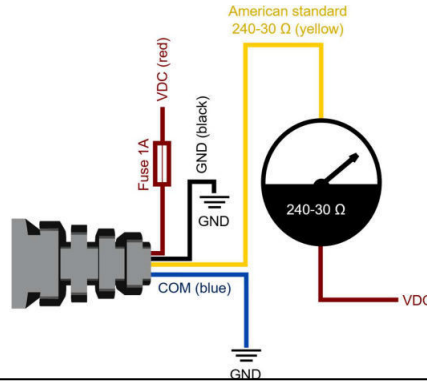
Type: Resistive	Signal out: 0 - 190 Ohm (European standard)	Signal wires: White, Blue
 <p>The diagram illustrates the wiring for the European standard. A 1A fuse is connected to the VDC (red) line. The common (COM) line is blue. The signal line is white. A meter with a scale from 0 to 190 Ohms is connected between the signal line and the VDC line. Ground (GND) is shown at the bottom.</p>		
Type: Resistive	Signal out: 240 - 30 Ohm (American standard)	Signal wires: Yellow, Blue
 <p>The diagram illustrates the wiring for the American standard. A 1A fuse is connected to the VDC (red) line. The common (COM) line is blue. The signal line is yellow. A meter with a scale from 240 to 30 Ohms is connected between the signal line and the VDC line. Ground (GND) is shown at the bottom.</p>		

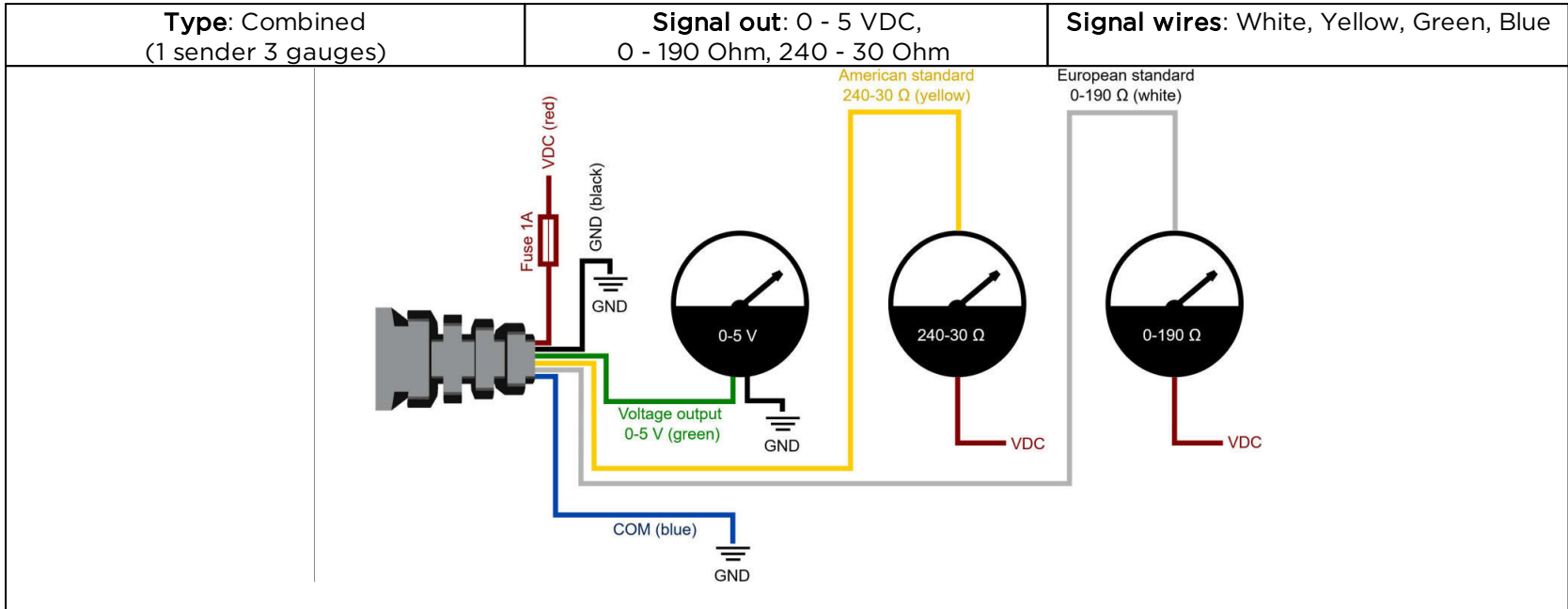
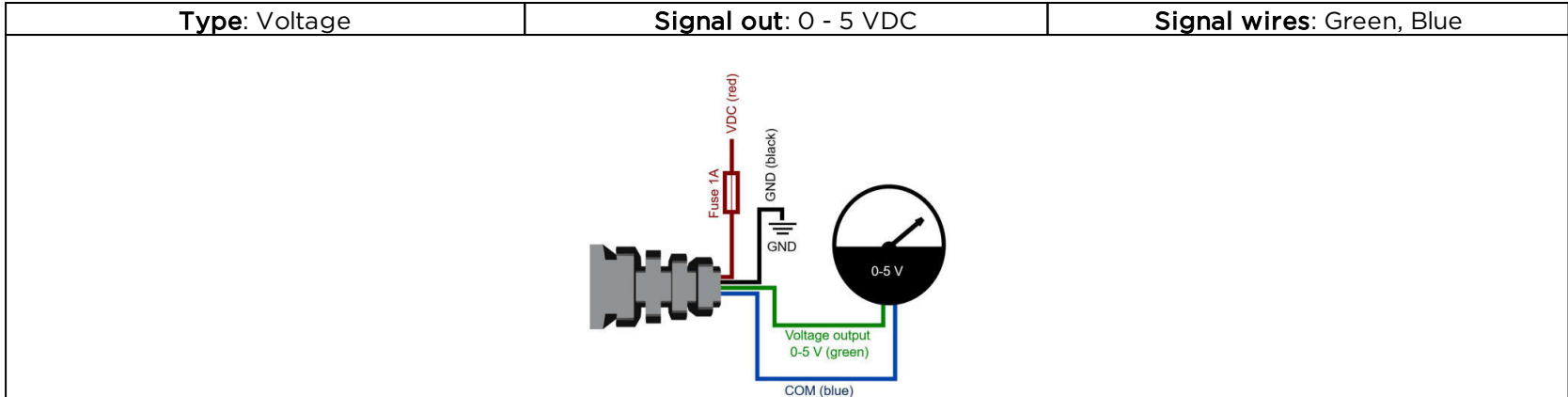

5.2 Simarine Specific Wiring

This manual illustrates the wiring on the two most commonly used Simarine expansion modules. However, the same wiring principles apply to any Simarine module that provides a compatible input type, whether voltage or resistance.

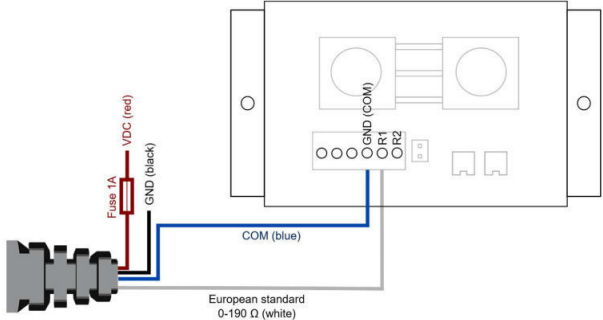
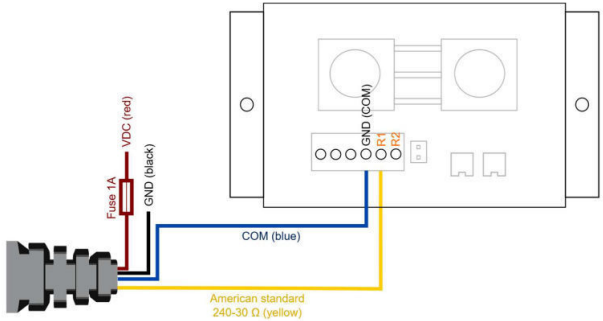
Type: Resistive SCX03	Signal out: 0 - 190 Ohm (European Standard)	Signal wires: White, Blue
 <p>The diagram shows a connector with three wires: a red wire labeled 'VDC (red)', a black wire labeled 'GND (black)', and a blue wire labeled 'COM (blue)'. The red wire passes through a 'Fuse 1A' before connecting to the 'GND (COM)' terminal on the module. The black wire connects to the 'R1' terminal, and the blue wire connects to the 'R2' terminal. Below the connector, it is noted as 'European standard 0-190 Ω (white)'.</p>		
Type: Resistive SCX03	Signal out: 240 - 30 Ohm (American Standard)	Signal wires: Yellow, Blue
 <p>The diagram shows a connector with three wires: a red wire labeled 'VDC (red)', a black wire labeled 'GND (black)', and a blue wire labeled 'COM (blue)'. The red wire passes through a 'Fuse 1A' before connecting to the 'GND (COM)' terminal on the module. The black wire connects to the 'R1' terminal, and the blue wire connects to the 'R2' terminal. Below the connector, it is noted as 'American standard 240-30 Ω (yellow)'.</p>		

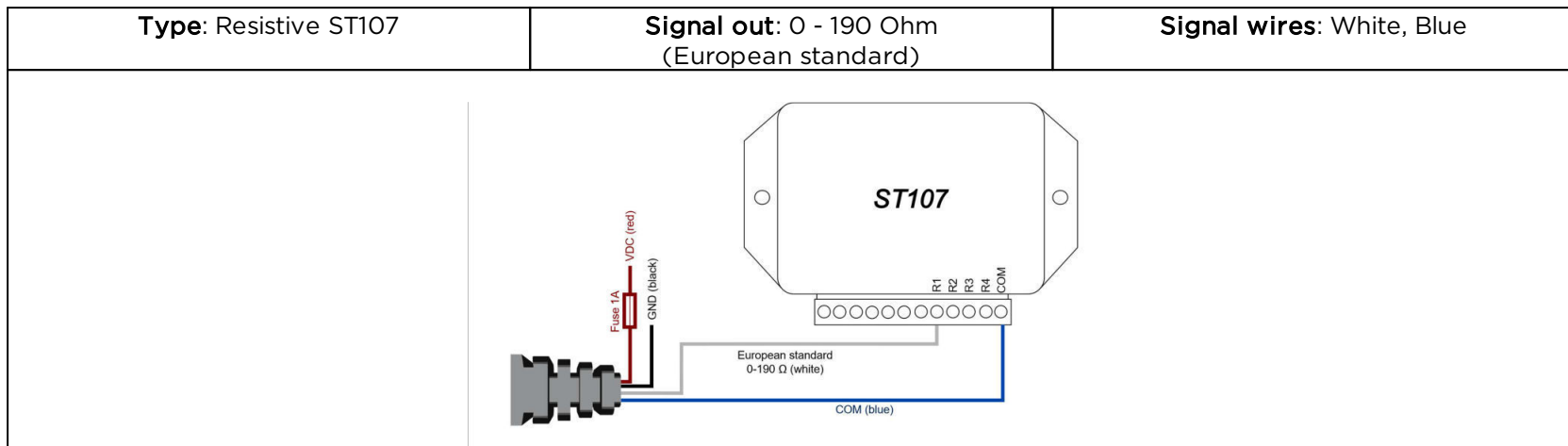
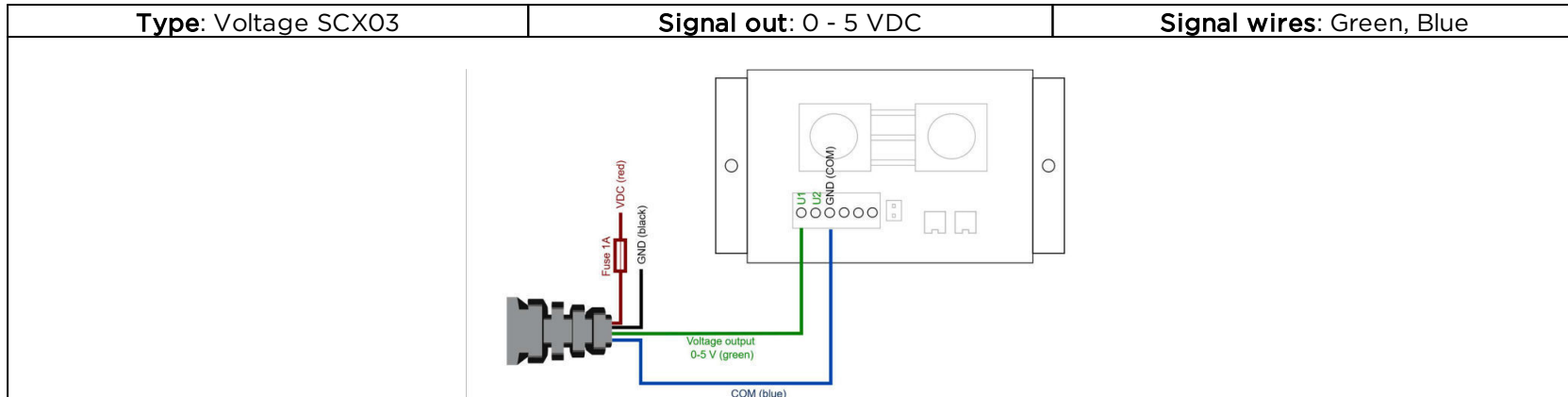

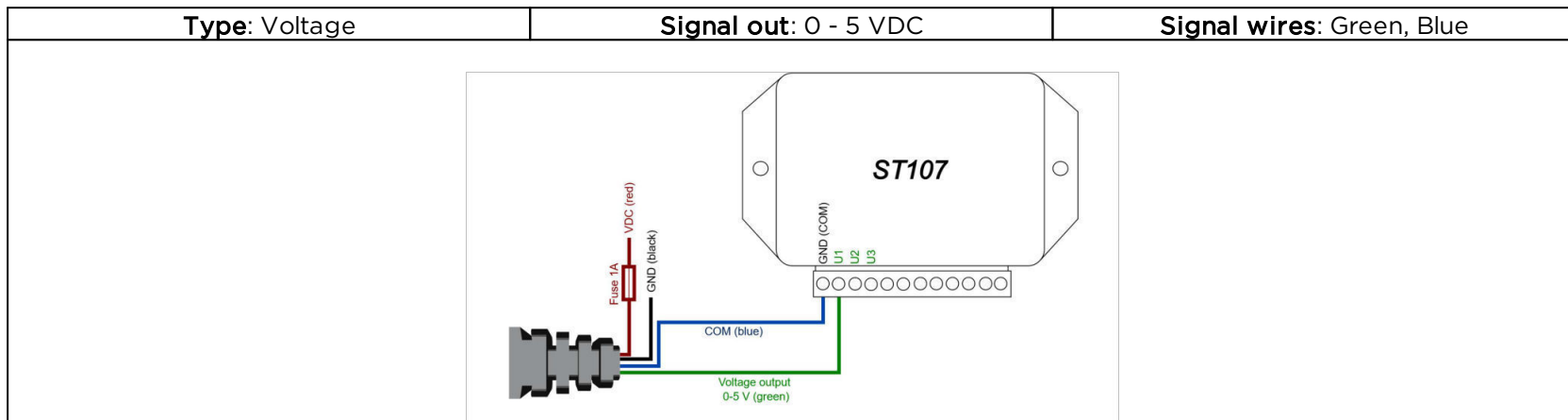
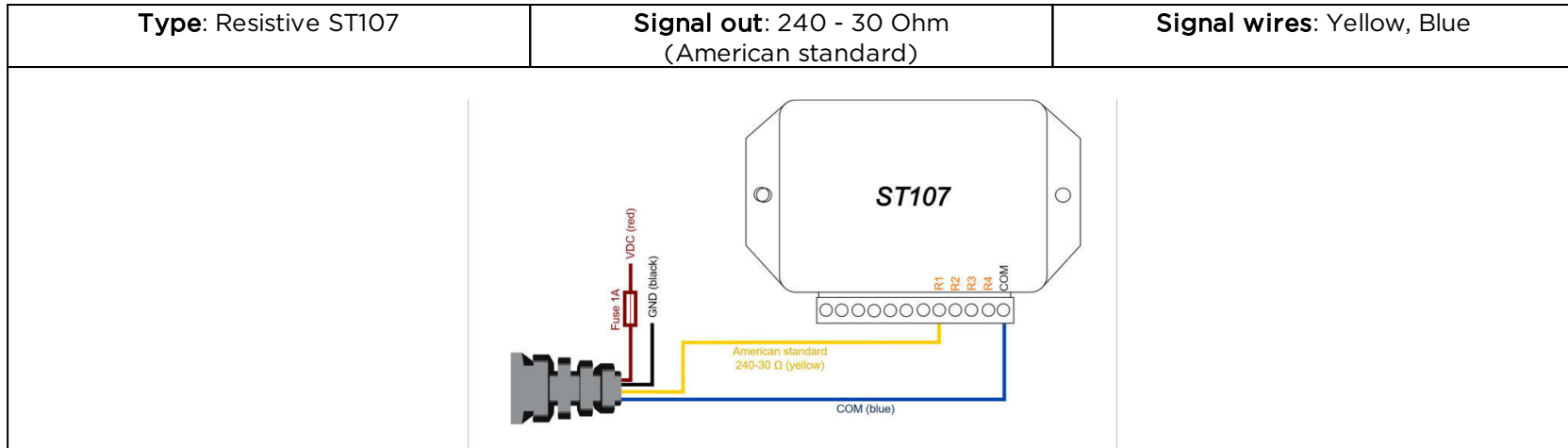

5.3 Victron Specific Wiring

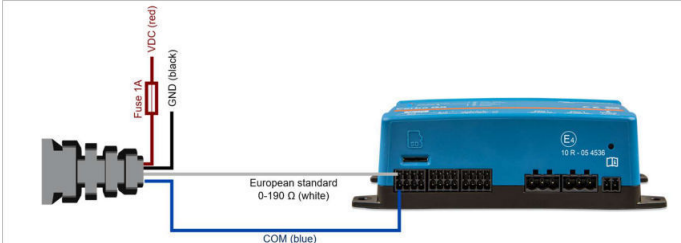
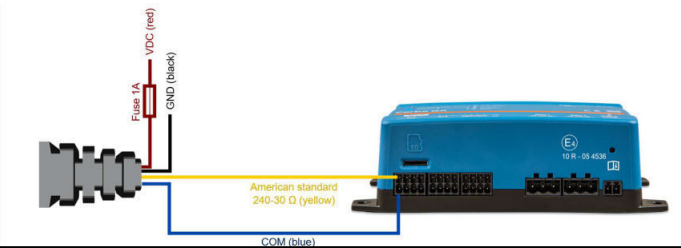
Type: Resistive	Signal out: 0 - 190 Ohm (European Standard)	Signal wires: White, Blue
 <p>The diagram shows a blue Victron device with a terminal block on the left. A red wire labeled 'VDC (red)' and a black wire labeled 'GND (black)' are connected to the top two terminals. A white wire labeled 'European standard 0-190 Ω (white)' is connected to the signal output terminal. A blue wire labeled 'COM (blue)' is connected to the ground terminal. A 1A fuse is shown in series with the VDC line.</p>		
Type: Resistive	Signal out: 240 - 30 Ohm (American Standard)	Signal wires: Yellow, Blue
 <p>The diagram shows a blue Victron device with a terminal block on the left. A red wire labeled 'VDC (red)' and a black wire labeled 'GND (black)' are connected to the top two terminals. A yellow wire labeled 'American standard 240-30 Ω (yellow)' is connected to the signal output terminal. A blue wire labeled 'COM (blue)' is connected to the ground terminal. A 1A fuse is shown in series with the VDC line.</p>		

5.4 Mixed System Wiring

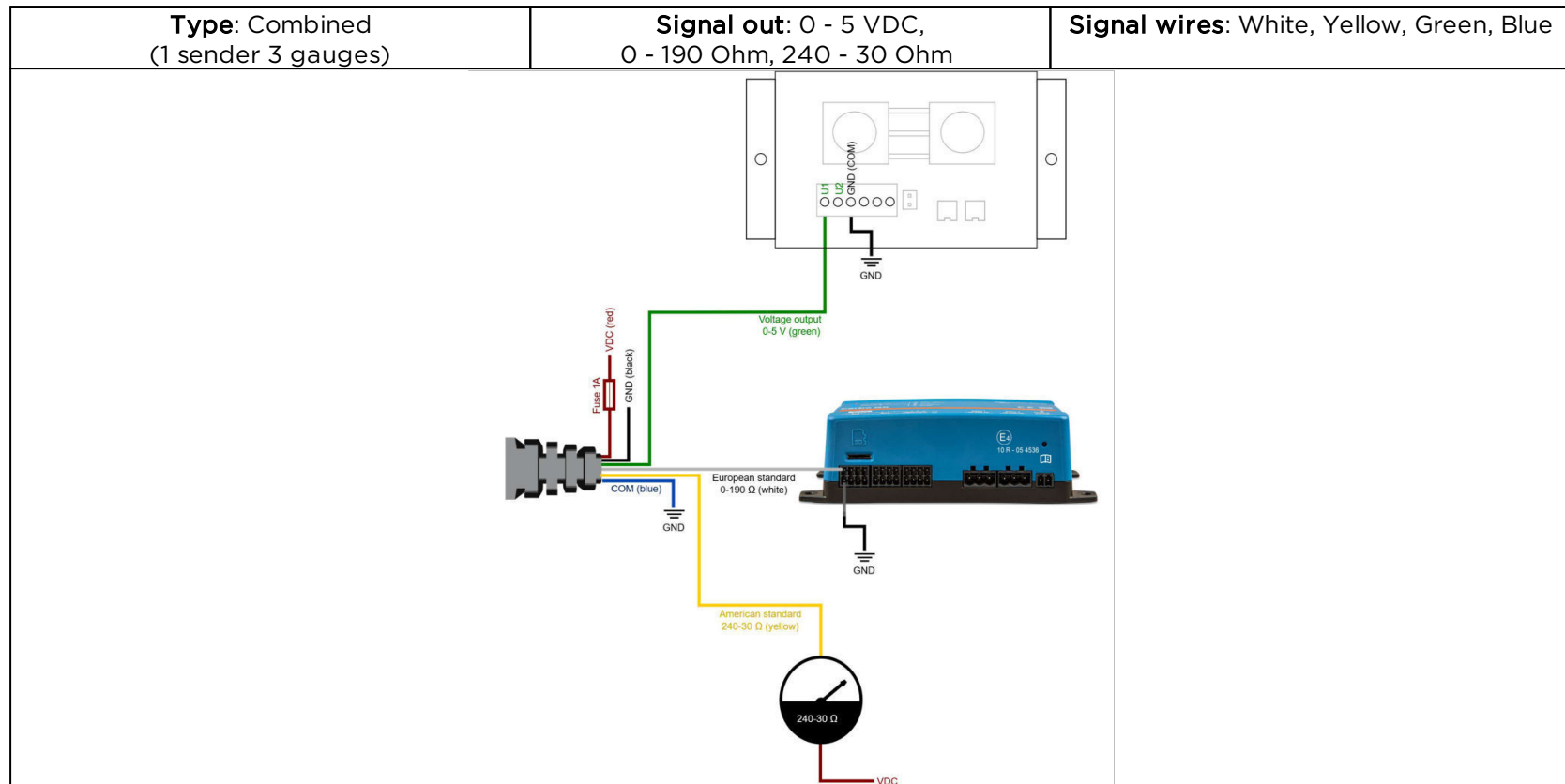

6. Sender Configuration

!

Do not configure the sender before it is mounted in its final position and the tank is completely empty. If the sender has been initialized beforehand, you must reset it to factory defaults and repeat the configuration process

6.1 First Time Configuration

Before configuring the sender, ensure that you have the latest version of the phone application installed and that Bluetooth is enabled. The sender must be mounted in its final location, and the tank must be empty. When you are ready to begin the configuration, launch the application.

STEP 1: Press "Scan for devices"

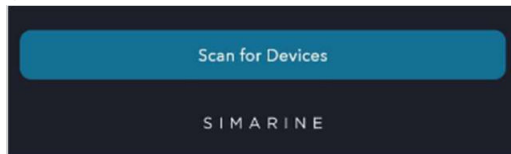

STEP 2: Select the tank sender that you want to configure.

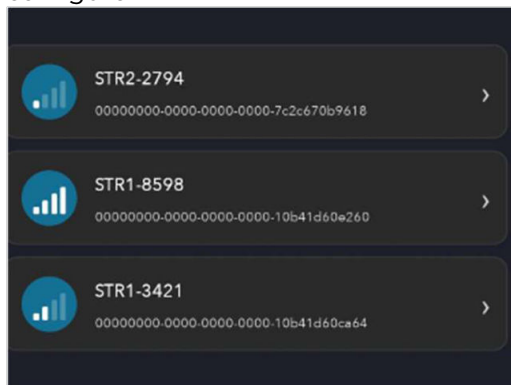

STEP 3: Name the tank sender, enter the height, the volume and the type of the tank.

It is possible to enable the Auto Height option in which case the tank sender will measure the height of the tank automatically.

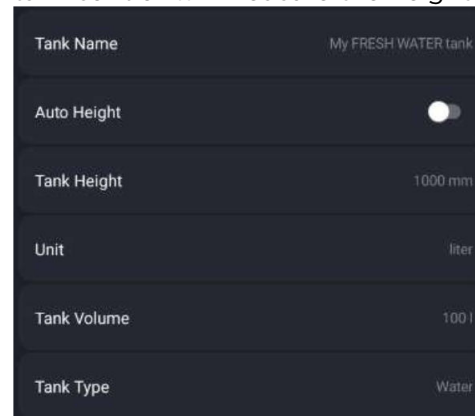

Press "Save" button to confirm the configuration.

How to configure the sender when the tank is not completely empty

If the tank is not completely empty, calibration is still possible as long as the distance between the sender and the liquid surface is at least 150 mm. If this distance is smaller, the sender cannot accurately measure the tank characteristics and the calibration **will not be correct**.

Adding a sender that is already configured

When adding a sender that has already been configured, the passkey is required. The passkey is located on the top of the sender. If you need to reconfigure a sender that has previously been configured, you must first perform a factory reset.

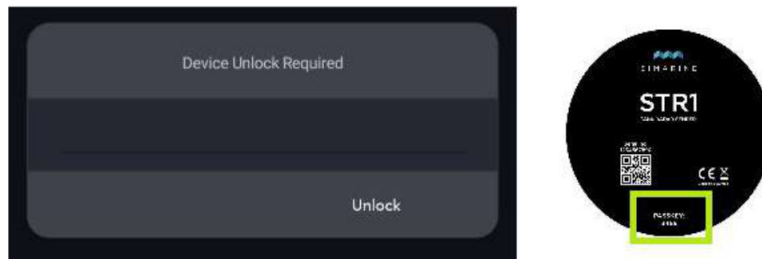

6.2 Manual Calibration of an irregular-shaped tank

By default, the automatic calibration configures the sender so that tank level calculations are based on two calibration points: **Empty** and **Full**. This method is ideal for rectangular tanks.

Adding more than two calibration points to tanks with regular, uniform shapes provides no additional benefit.

To achieve maximum precision when monitoring tanks with irregular shapes, you can manually configure multiple calibration points.

Below is an example showing multiple calibration points for tanks of various shapes. As a rule of thumb, add a calibration point for every significant change in the tank's shape. Be sure to also read the practical tip for calibrating irregular-shaped tanks further down on this page.

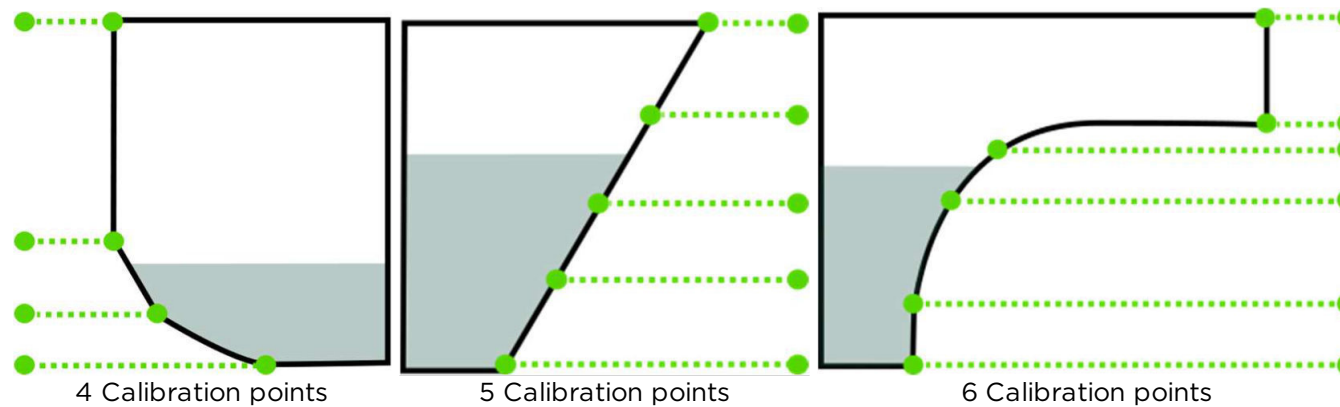

Practical tip for calibrating an Irregular-shaped tank

To simplify the calibration process—even for irregular-shaped tanks—it is helpful to know that adding calibration points at fixed volume intervals can provide equally accurate, or even superior, results.

For example, adding a calibration point every 10 L in a 100 L tank results in 10 calibration points. This method removes the tank's shape from the equation, as the calibration points automatically redistribute according to the measured liquid level.

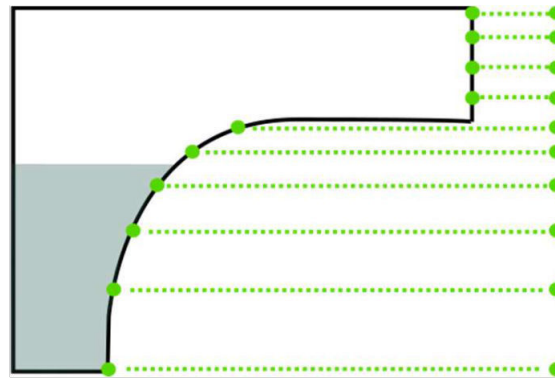

Calibrating a tank using the fixed volume intervals - (Recommended method)
10 calibration points (volume interval: 10L)

6.3 Manual Calibration

For each calibration point, you must define both the height of the point and the corresponding volume of liquid. The height can be entered manually, or you can use the current height detected by the sender. This is especially useful when using the recommended fixed-volume-interval calibration method.

The first calibration point should be set at the bottom of the tank (the empty calibration point).

STEP 1:

In the top-left corner of the application, tap the gear open the menu. From the menu select “Device Calibration”.

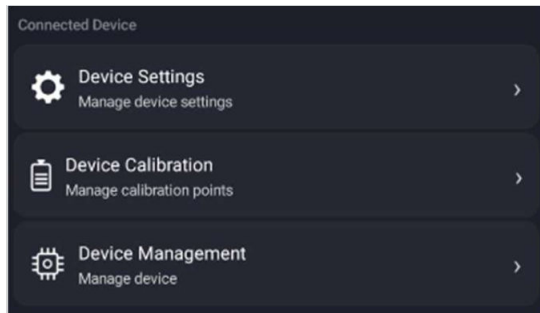

STEP 2: Choose “Add Calibration Point”

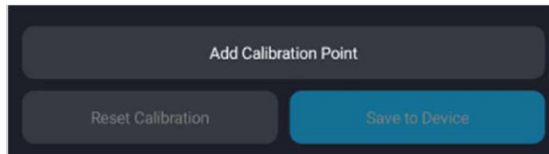

STEP 3:

Enter the volume for the calibration point and the distance from the bottom of the tank.

If the tank is filled to the corresponding calibration point (for example, 0 L indicates an empty tank), you may select “Use Current Sensor Value.” The system will then automatically apply the distance currently measured by the sender.



Press “Save” button to confirm the configuration.

STEP 4:

Repeat the process and add at least 2 calibration points.

For the recommended calibration method using fixed volume intervals (as described on the previous page), continue adding calibration points at the chosen fixed interval (e.g., 10 L).

Create one calibration point for each interval until you reach the full-tank calibration point.

By starting with an empty tank, you can use current sender value for each calibration point, by selecting “Use Current Sensor Value”.

Once you are done configuring the calibration points, select “Save to Device”.

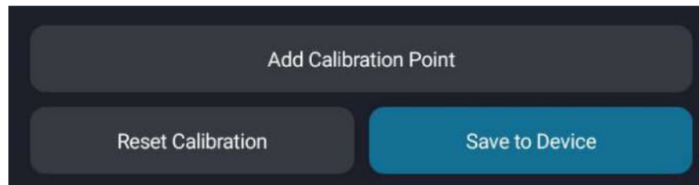

6.4 Firmware upgrade

Before upgrading the firmware, make sure you have installed the latest version of the phone application.

STEP 1:

In the top-left corner of the application, tap the gear icon to open the menu.

From the menu, select "Device Management."

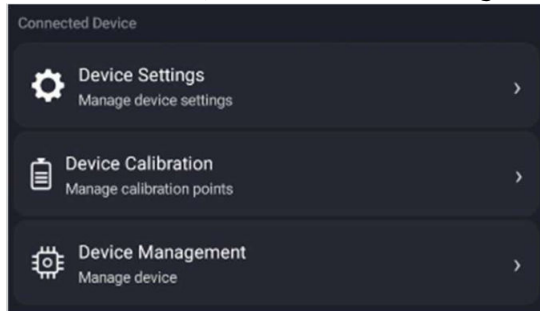

STEP 2: Choose "Firmware update"

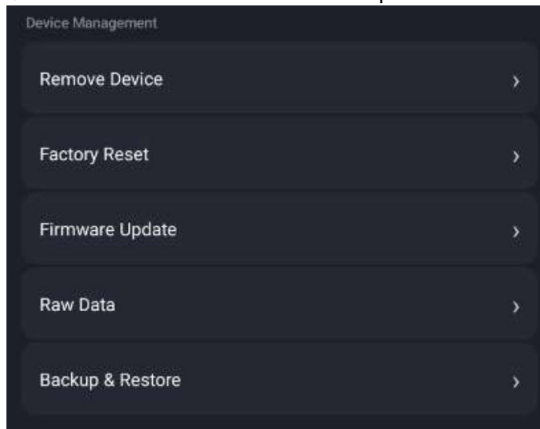

STEP 3: Confirm the update. The process may take a few minutes to complete.

STEP 4:

Please wait for the device to reboot.

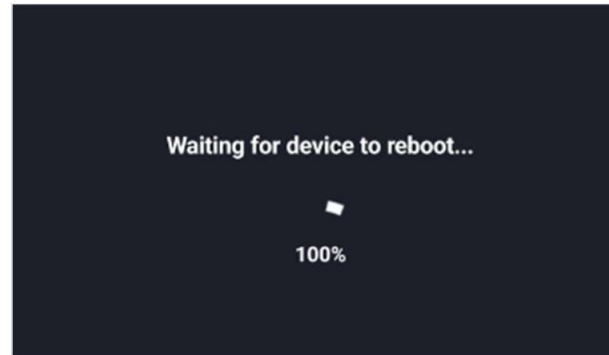

STEP 5:

After the reboot, the application will attempt to reconnect to the sender.

Because the reboot process can take some time, the application may fail to reconnect on the first attempt. If this happens, wait a few seconds and try again, or restart the phone application.

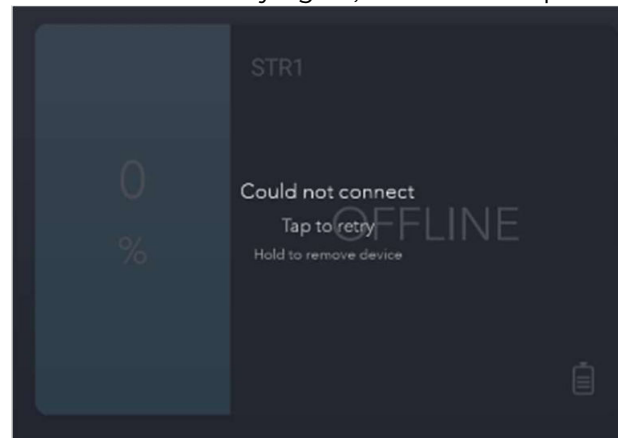

6.5 Factory Reset

Resetting the sender to factory default settings erases all stored configurations. This function should be used when the sender has not been calibrated properly and requires reconfiguration.

STEP 1:

In the top-left corner of the application, tap the gear icon to open the menu. From the menu, select "Device Management"

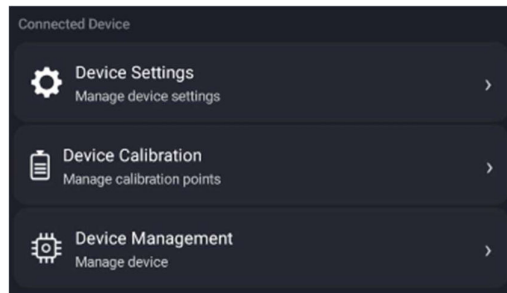

STEP 2: Choose "Factory Reset".

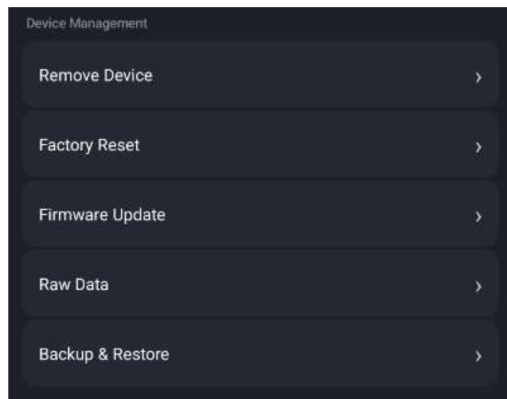

STEP 3: Confirm the reset.

7. Technical specification

IP rating	IP67
Operating	
Operating voltage	8 - 35 VDC
Operating temperature range	-20°C - 70°C (-4°F - 158°F)
Tank size	
Minimum tank size	150 mm (15cm or 5.91 inch)
Maximum tank size	2000mm (2m or 78.74 inch)
Maximum wall thickness	10mm (0.39 inch)
Sampling frequency	1 Hz
Accuracy	± 2 %
Analogue signal outputs	
Standard European gauges	0 - 190 Ohm
Standard American gauges	240 - 30 Ohm
Voltage	0 - 5 VDC
<u>All three signal outputs operate simultaneously, thereby enabling concurrent tank-level monitoring through multiple gauges</u>	
Digital monitoring	
Connectivity	Bluetooth (Phone app)



S I M A R I N E

Safe Voyage.

SIMARINE marine electronics

www.simarine.net

©2026 All rights reserved